



**DESCRIPTION:**

**5.2KVDC Isolated DC/DC Converters for IGBT drivers**

The TPJXXX-2W is 5.2KVDC isolated DC/DC-converters for IGBT drivers in a SIP package. Their ultra low isolation capacitance can improve the capability of anti-interference. The built-in common-ground mode of the unique asymmetric voltage output mode reduces the driver loss of IGBT driver. They feature short-circuit protection and auto-recovery , and can be widely used in: General inverter, AC servo drive system, Electric welding machine, Uninterruptible power supply (UPS) . They offer the ideal solution in many space critical applications for board level power distribution. The series offers smaller size, improved efficiency, lower output ripple noise.

**FEATURES**

RoHS compliant	Max capacitive load: 220uF	DC/DC-converters for IGBT drivers
Operating temperature: -40°C to 105°C	Footprint 1.91cm <sup>2</sup>	UL 94V-0 package material
No heatsink required	5.2KVDC isolation	SIP package style
short-circuit protection	/	/

**SELECTION GUIDE**

Part Number	Nominal Input Voltage	Output Voltage	Output Current	Efficiency (Min.)
	V	V	mA	%
TPJ0518/2.5-2W	5	+18/-2.5	+80/-80	75-80
TPJ0518/3.5-2W	5	+18/-3.5	+80/-80	75-80
TPJ0520/4-2W	5	+20/-4	+80/-40	75-80
TPJ0520/5-2W	5	+20/-5	+80/-40	75-80
TPJ1515/9-2W	15	+15/-8.7	+80/-40	76-80
TPJ1215/9-2W	12	+15/-8.7	+80/-40	76-80
TPJ1215/5-2W	12	+15/-5	+80/-40	75-80
TPJ1215/3-2W	12	+15/-3	+93/-185	75-80
TPJ1215/3.5-2W	12	+15/-3.5	+111/-111	75-80
TPJ1220/5-2W	12	+20/-5	+100/-100	75-80
TPJ1517/8.7-2W	15	+17/-8.7	+80/-40	77-80
TPJ1515/2.5-2W	15	+15/-2.5	+100/-100	77-78
TPJ2415/3-2W	24	+15/-3	+66/-333	75-80
TPJ2415/3-O-2W	24	+15/-3	+111/-111	75-80
TPJ2415/4-2W	24	+15/-4	+120/-120	75-80
TPJ2420/4-2W	24	+20/-4	+100/-100	75-80
TPJ2420/5-2W	24	+20/-5	+50/-200	75-80

The above part number with "L" Suffix are 90° bent pins power converters, for example "TPJ2420/4L-2W"

**INPUT CHARACTERISTICS**

Parameter	Conditions	Min.	Typ.	Max.	Units
Voltage range	24V input	22.8	24	25.2	VDC
Voltage range	15V input	13.5	15	16.5	VDC
Voltage range	12V input	10.8	12	13.2	VDC
Voltage range	5V input	4.5	5	5.5	VDC

**ABSOLUTE MAXIMUM RATINGS**

Short-circuit protection	continuous
Lead temperature 1.5mm from case for 10 seconds	300°C
Input voltage Vin, TPJ24XX-2W	28V
Input voltage Vin, TPJ15XX-2W	18V
Input voltage Vin, TPJ12XX-2W	15V
Input voltage Vin, TPJ05XX-2W	7V

**OUTPUT CHARACTERISTICS**

Parameter	Conditions	Min.	Typ.	Max.	Units
+Vo (TPJ0518/2.5-2W)	Vin=5VDC, Pin6 & Pin7 +Io= +80mA	16.74	17.64	18.54	VDC
-Vo (TPJ0518/2.5-2W)	Vin=5VDC, Pin5 & Pin6 +Io= -80mA	-2.28	-2.4	-2.53	VDC
+Vo (TPJ0518/3.5-2W)	Vin=5VDC, Pin6 & Pin7 +Io= +80mA	16.74	17.64	18.54	VDC
-Vo (TPJ0518/3.5-2W)	Vin=5VDC, Pin5 & Pin6 +Io= -80mA	-3.13	-3.3	-3.67	VDC
+Vo (TPJ0520/4-2W)	Vin=5VDC, Pin6 & Pin7 +Io= +80mA	18.8	19.8	20.8	VDC
-Vo (TPJ0520/4-2W)	Vin=5VDC, Pin5 & Pin6 +Io= -40mA	-3.78	3.98	-4.18	VDC
+Vo (TPJ0520/5-2W)	Vin=5VDC, Pin6 & Pin7 +Io= +80mA	18.5	19.5	20.5	VDC
-Vo (TPJ0520/5-2W)	Vin=5VDC, Pin5 & Pin6 +Io= -40mA	-4.95	-5.2	-5.45	VDC
+Vo(TPJ1515/9-2W, TPJ1215/9-2W)	Vin=15VDC/12VDC, Pin6 & Pin7 +Io=+80mA	14.25	15	15.75	VDC
-Vo(TPJ1515/9-2W, TPJ1215/9-2W)	Vin=15VDC/12VDC, Pin5 & Pin6 -Io=-40mA	-8	-8.7	-9.4	VDC
+Vo (TPJ1215/3-2W)	Vin=12VDC, Pin6 & Pin7 +Io=+93mA	14.25	15	15.75	VDC
-Vo (TPJ1215/3-2W)	Vin=12VDC, Pin5 & Pin6 -Io= -185mA	-2.76	-3	-3.24	VDC
+Vo (TPJ1215/3.5-2W)	Vin=12VDC, Pin6 & Pin7 +Io=+111mA	13.8	15	15.38	VDC
-Vo (TPJ1215/3.5-2W)	Vin=12VDC, Pin5 & Pin6 -Io= -111mA	-2.97	-3.5	-3.63	VDC
+Vo (TPJ1215/5-2W)	Vin=12VDC, Pin6 & Pin7 +Io=+80mA	14.25	15	15.75	VDC
-Vo (TPJ1215/5-2W)	Vin=12VDC, Pin5 & Pin6 -Io= -40mA	-4.6	-5	-5.4	VDC
+Vo (TPJ1220/5-2W)	Vin=12VDC, Pin6 & Pin7 +Io=+100mA	19.6	20	20.4	VDC
-Vo (TPJ1220/5-2W)	Vin=12VDC, Pin5 & Pin6 -Io= -100mA	-5.15	-5.0	-5.3	VDC
+Vo(TPJ1517/8.7-2W)	Vin=15VDC, Pin6 & Pin7 +Io=+80mA	16.15	17	17.85	VDC
-Vo(TPJ1517/8.7-2W)	Vin=15VDC, Pin5 & Pin6 -Io=-40mA	-8.00	-8.7	-9.40	VDC
+Vo(TPJ1515/2.5-2W)	Vin=15VDC, Pin6 & Pin7 +Io=+100mA	14.25	15	15.75	VDC
-Vo(TPJ1515/2.5-2W)	Vin=15VDC, Pin5 & Pin6 -Io=-100mA	-2.35	-2.5	-2.85	VDC
+Vo(TPJ2415/3-2W)	Vin=24VDC, Pin6 & Pin7 +Io=+66mA	14.25	15	15.75	VDC
-Vo(TPJ2415/3-2W)	Vin=24VDC, Pin5 & Pin6 -Io= -333mA	-2.76	-3	-3.24	VDC
+Vo(TPJ2415/3-O-2W)	Vin=24VDC, Pin6 & Pin7 +Io=+111mA	14.25	15	15.75	VDC
-Vo(TPJ2415/3-O-2W)	Vin=24VDC, Pin5 & Pin6 -Io= -111mA	-2.76	-3	-3.24	VDC
+Vo(TPJ2415/4-2W)	Vin=24VDC, Pin6 & Pin7 +Io=+120mA	14.25	15.3	16.05	VDC
-Vo(TPJ2415/4-2W)	Vin=24VDC, Pin5 & Pin6 -Io= -120mA	-3.96	-4.16	-4.36	VDC
+Vo(TPJ2420/4-2W)	Vin=24VDC, Pin6 & Pin7 +Io=+100mA	19	20	21	VDC
-Vo(TPJ2420/4-2W)	Vin=24VDC, Pin5 & Pin6 -Io= -100mA	-3.68	-4	-4.32	VDC
+Vo (TPJ2420/5-2W)	Vin=24VDC, Pin6 & Pin7 +Io=+50mA	19	20	21	VDC
-Vo (TPJ2420/5-2W)	Vin=24VDC, Pin5 & Pin6 -Io= -200mA	-4.6	-5	-5.4	VDC
Output Voltage Accuracy	See tolerance envelope graph				
Line Regulation	High Vin to Low Vin	-	±1.2	±1.5	-
Temperature Coefficient	Full load	-	-	±0.03	%/°C
Linear Regulation	Input voltage range Positive output		±1.1	±1.3	%%
Linear Regulation	Input voltage range Negative output		±1.1	±1.3	%%
Load Regulation	10%-100%load Positive output		5	8	%
Load Regulation	10%-100%load Negative output		10	13	%

**GENERAL CHARACTERISTICS**

Parameter	Conditions	Min.	Typ.	Max.	Units
Short Circuit Protection		Continuous, self-recovery			
Ripple & Noise*	20MHz bandwidth	-	100	250	mVp-p

**ISOLATION CHARACTERISTICS**

Parameter	Conditions	Min.	Typ.	Max.	Units
Isolation test voltage	Input-output, with the test time of 1 minute and the leak current lower than 1mA	5200		-	VDC
Resistance	Input-output, Isolation voltage 500VDC	1000	-	-	MΩ
Capacitance	Input-output, 100KHz/0.1V	-	5	10	pF

**GENERAL CHARACTERISTICS**

Parameter	Conditions	Min.	Typ.	Max.	Units
Storage Humidity	Non-condensing	-	-	95	%RH
Switching frequency	Full load, nominal input voltage	-	100	300	KHz
MTBF	MIL-HDFK-217F@25°C	3500	-	-	K hours
Cooling Method	Free convection				

**TEMPERATURE CHARACTERISTICS**

Parameter	Conditions	Min.	Typ.	Max.	Units
Operating Temperature	Derating when operating temperature up to 85°C,	-40	-	105	°C
Storage Temperature		-55	-	125	°C
Pin Welding Resistance	Welding spot is 1.5mm away from the casing, 10	-	-	300	°C
Casing Temperature Rise	Ta=25°C, nominal input, full load output	-	25	-	°C

**TEMPERATURE DERATING GRAPHS**

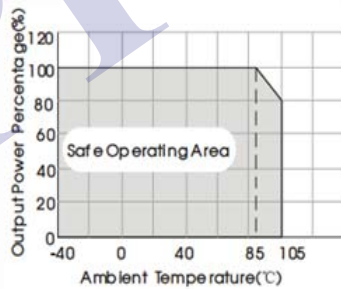

**MECHANICAL DIMENSIONS**

90° bent pins power converters(part number with "L" Suffix)

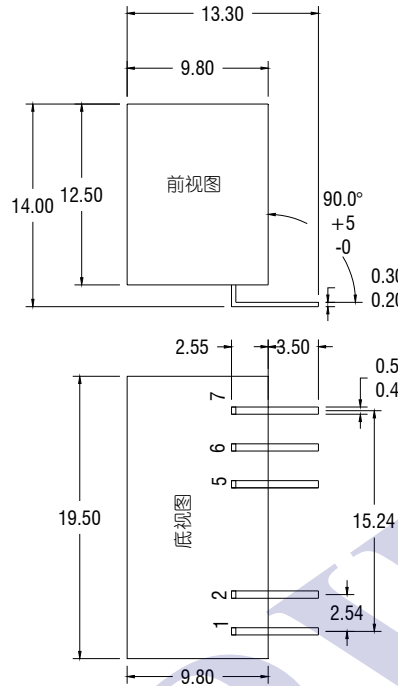
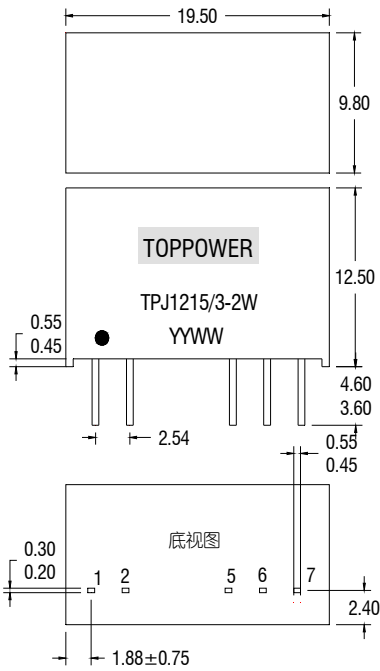

PIN CONNECTIONS	
Output	
Pin	Function
1	+Vin
2	GND
5	-Vout
6	0V
7	+Vout

Weight: 4.3g

All dimensions in mm  $\pm 0.25$ mm. All pins on a 2.54mm pitch and within  $\pm 0.25$ mm of true position.

**RECOMMENDED FOOTPRINT DETAILS**

**TUBE OUTLINE DIMENSIONS**

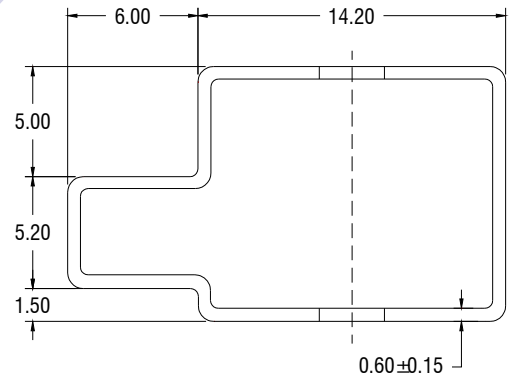
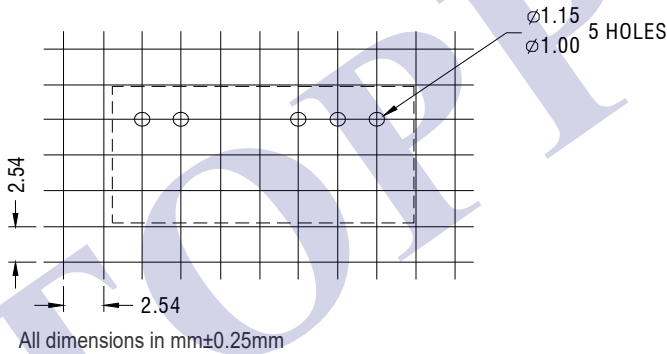

Unless otherwise stated all dimensions in  $\pm 0.5$ mm. Tube length : 525mm $\pm 2$ mm. Tube Quantity : 25

**RECOMMENDED FOOTPRINT DETAILS**

**1. Typical application**

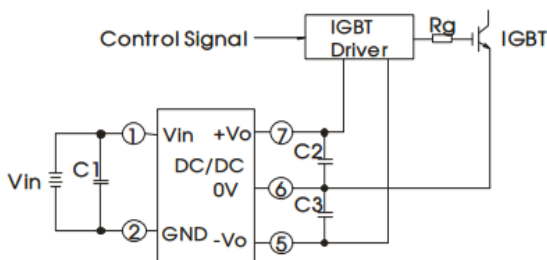

C1/C2/C3
100uF/35V (Low internal resistance capacitance)

Note: On both ends of capacitance C2 and C3 shunt respectively a capacitance value in 1uF -10uF ceramic capacitors

EMC solution-recommended circuit

recommended circuit 1

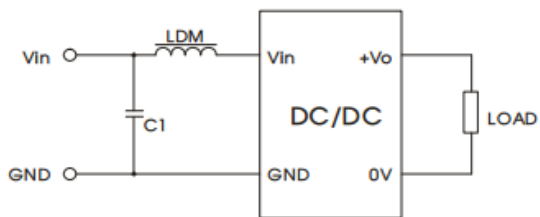

Input voltage (VDC)		12/15
EMI	C1	4.7μF /50V
	LDM	12μH

Note: It is not allowed to connect modules output in parallel to enlarge the power

recommended circuit 2

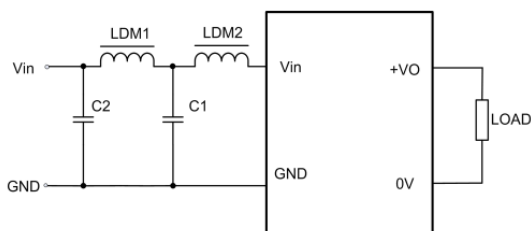

Input voltage (VDC)		12/15
EMI	C1,C2	4.7uF/50V
EMI	LDM1	12uH
EMI	LDM2	47uH

TOPOPOWER